

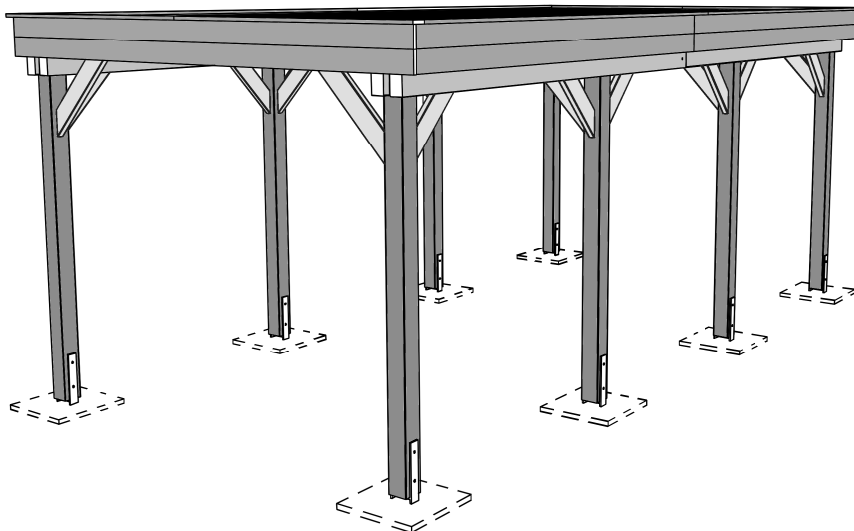

# Montage-, Bedienungs- und Wartungsanleitung

en	ASSEMBLY, USER AND MAINTENANCE INSTRUCTIONS
fr	NOTICE DE MONTAGE, D'UTILISATION ET D'ENTRETIEN
it	ISTRUZIONI DI MONTAGGIO, USO E MANUTENZIONE



## **PREMIUM-CARPORT** SN 3,0 kN/m<sup>2</sup>

**Art.-Nr.: 609.3260.50.00**

Stand 1834

- de -

**Sehr geehrte Kundin, sehr geehrter Kunde,  
danke, dass Sie sich für ein weka – Produkt entschieden haben.**

- Lesen Sie diese Anleitung vor dem Aufbau bitte vollständig durch, um Montagefehler oder Beschädigungen zu vermeiden.
- **WICHTIG!**  
**Prüfen Sie bitte sofort anhand der Packliste, ob das weka-Produkt vollständig und unbeschädigt bei Ihnen angekommen ist.**
- Bitte vernichten Sie die Packliste erst nach Ablauf der Garantiezeit. Diese Liste dient Ihnen zur Kontrolle auf Vollständigkeit der Einzelteile und ist mit dem Kaufbeleg aufzubewahren. Eventuelle Beanstandungen können mit Hilfe dieser Liste problemlos behoben werden. Die Pos.-Nummern der Packliste stimmen nicht mit den Pos.-Nummern folgender Montageanleitung überein.
- Wir empfehlen Ihnen die Montage mit 2 Personen durchzuführen.
- Zur Verhütung von Unfällen ist zu vermeiden, dass sich Kinder während der Montage in unmittelbarer Nähe befinden.
- Weiterentwicklungen im Sinne des technischen Fortschritts behalten wir uns vor. So können geringfügige Abweichungen in den Darstellungen entstehen.
- Verpackungsmaterial nicht einfach wegwerfen! Papier-, Pappe- und Wellpappeverpackungen, sowie Kunststoffverpackungsteile sollten in die entsprechenden Sammelbehälter gegeben werden.

## **EMPFEHLUNGEN**

- Bitte bohren Sie alle Schraubverbindungen vor, um Beschädigungen an den Holzteilen zu vermeiden! Folgendes Zeichen macht Sie während der Anleitung nochmals darauf aufmerksam:



- Schützen Sie das Holz vor stundenlanger, direkter Sonneneinwirkung oder Feuchtigkeit.
- Holz ist ein Naturprodukt. Verschiedenartige Färbungen, Äste und Rissbildung sind normal und haben keinen Einfluss auf die Statik.
- Voraussetzung für eine statikgerechte Montage ist die Verankerung der Pfosten mittels H-Pfostenträgern in Betonfundamenten. Die Pfostenträger sind als weka-Zubehör gegen Aufpreis erhältlich.
- **Den Fundamentplan erhalten Sie bei Ihrem Fachhändler!**
- Um das exakte Ausrichten der H-Anker zu erleichtern, kennzeichnen Sie die erforderlichen Pfostenabstände auf einem Richtholz und befestigen dort die Anker mit Schraubzwingen.
- Danach hängen Sie die H-Anker in die zuvor ausgehobenen Fundamentlöcher.
- Die benötigte Dachneigung von 1% (Gefälle in Richtung Rückseite) erreichen Sie, indem Sie die Höhe der Pfostenträger variieren. Das erforderliche Gefälle erreichen Sie auch alternativ durch die Kürzung der Pfosten.
- Nachdem Sie die Löcher mit Beton C25/30 aufgefüllt haben, müssen die Fundamente mindestens 3 Tage lang aushärten.
- Die mitgelieferte Dachpappe dient als erste Schicht des Dachbelages, sie ist für sich alleine kein dauerhafter Schutz vor der Witterung. Einen sicheren Schutz erhalten Sie erst durch eine zweite Schicht (Lage), die Sie nach Ihren Vorstellungen (z.B. Dachpappe oder Schindeln) gemäß geltender Verlegeregeln aufbringen müssen. Anderenfalls ist mit Schäden an Ihrem weka-Produkt zu rechnen.
- Die maximale Schneelast dieses Carports beträgt 3,0 kN/m<sup>2</sup>, daraus ergibt sich eine maximale Schneehöhe von 1,50 m. Ab dieser Schneehöhe ist das Dach zu beräumen.

## Garantiebestimmungen der weka Holzbau GmbH

Wir gewähren Ihnen zu nachfolgenden Konditionen – jedoch nur auf die Holzteile unserer Produkte (weka-Produkt genannt), nicht auf damit verbundene Bauteile oder Bestandteile des weka-Produkts aus anderem Material als Holz – ab Lieferdatum 5 Jahre Garantie auf Funktion. Innerhalb der Garantiezeit werden fehlerhafte Teile oder fehlende Teile der Ware oder die Ware selbst nach unserer Wahl ersetzt. Vom Garantieumfang erfasst ist lediglich der kostenlose Ersatz des jeweils mangelhaften oder defekten Holzteils. Nicht im Garantieumfang enthalten sind Folge- oder Zusatzkosten, insbesondere keine Liefer- und Auf- oder Umbaukosten.

Die Garantie ist ausgeschlossen, wenn:

- von der jeweiligen Montageanleitung abgewichen wurde,
- Veränderungen (zusätzliche An- oder Umbauten) an dem Produkt im Vergleich zur Montageanleitung vorgenommen wurden,
- die jeweils angegebenen Belastungsgrenzen (z.B. Schneelast usw.) überschritten wurden,
- das weka-Produkt falsch gegründet (Fundament / Bodenplatte o.ä.) wurde, insbesondere bei Verstößen gegen die Regeln der Baukunst,
- unterlassene oder nicht ausreichende Pflege (Wartung: Holzschutz, Holzanstrich usw.) des Holzes vorgenommen wurde.
- Windgeschwindigkeiten über Stärke 7, Naturkatastrophen oder gewaltsame Einwirkungen den Schaden am weka-Produkt verursacht haben.
- der Mangel in holztypischen Farbveränderungen, Rissbildungen, Verwerfungen, Schwinden, Quellen oder ähnlichen normalen, in der Natur des Werkstoffes „Holz“ begründeten Veränderungen besteht.

Garantieansprüche können nur in Verbindung mit Originalpackzettel und Originalkaufbeleg in Anspruch genommen werden und müssen innerhalb der Garantiezeit schriftlich, per Telefax oder per e-Mail geltend gemacht werden. Anspruchsvoraussetzung ist eine unverzügliche Anzeige des Mangels bzw. des Schadens in Form einer geordneten Darstellung des Schadens in Bild und Text.

Garantieansprüche sind zu richten an:

weka Holzbau GmbH, Johannesstraße 16, 17034 Neubrandenburg  
Fax: 0395/42908-83; e-Mail: info@weka-holzbau.com

## WERKZEUG

Folgendes Werkzeug sollten Sie vor Beginn der Montage zurecht gelegt haben.

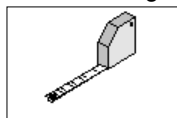

Bandmaß



Wasserwaage

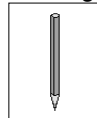

Bleistift

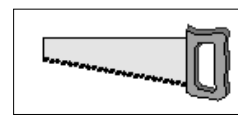

Säge



Bohrmaschine



Elektroschrauber

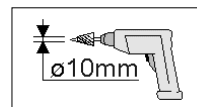

Kegelbohrer

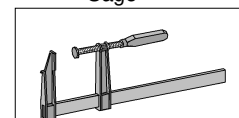

Schraubzwingen

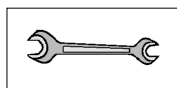

Schraubenschlüssel

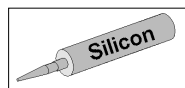

Silicon

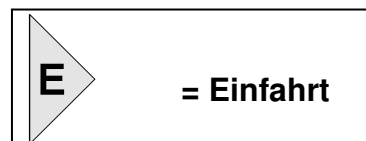

= Einfahrt

## **HINWEIS**

In regelmäßigen Abständen sollten die Verschraubungen überprüft und nachgezogen werden. Dieses Produkt ist überwiegend aus Massivholz gefertigt und da es sich bei dem Werkstoff Holz um ein Naturprodukt handelt, kann es vorkommen das durch extreme Witterungseinflüsse, insbesondere nach langen Wärmeperioden, sich Trockenrisse bilden. Diese Trockenrisse sind keinesfalls ein Qualitätsmängel, sondern eine natürliche Erscheinung und je nach Wetterlage können sich diese Risse bis auf ein Minimum wieder verschließen.

Darüber hinaus haben diese Trockenrisse, welche in Längsrichtung des Holzes auftreten, keinen Einfluss auf die Festigkeit und Belastbarkeit des Materials. Das heißt, die statischen Eigenschaften werden nicht beeinträchtigt.

- en -

## Dear customer

Thank you very much for choosing a weka product.

- Read these instructions through completely before assembling your product in order to avoid errors in assembly or damage.
- **IMPORTANT**  
**Please use the enclosed packing list to check immediately that your weka product has been delivered complete and intact.**
- Please do not dispose of the packing list before the guarantee period has expired. This list enables you to check that all the individual parts are present. It should be retained along with the proof of purchase. Any complaints which may arise can probably be easily rectified with this list. The item numbers on the packing list do not correspond to the item numbers in the following assembly instructions.
- We recommend that 2 people carry out the assembly.
- In order to prevent accidents, we recommend that children are kept out of the direct vicinity during assembly.
- We reserve the right to make further technological developments. This means that there may be minor deviations in the illustrations.
- Please do not simply throw away the packaging material. Paper, card and corrugated board as well as plastic packaging materials should be placed in the correct collection containers.

## RECOMMENDATIONS

- Please drill pilot holes for all screw connections to avoid damaging the wood. The following symbol in the instructions will indicate when this is necessary:



- Protect the wood from hours of direct sunlight and moisture.
- Wood is a natural product. Fluctuations in colour, knots and cracks are normal and have no influence on the statics.
- A prerequisite for successful assembly, is the anchoring of the studs in the concrete foundation using H stud supports. The stud supports are available as weka accessories for an additional cost.
- **A foundation plan can be obtained from your specialist dealer!**
- In order to facilitate the precise alignment of the H anchors, mark the necessary post clearances on a piece of guide wood and fix the anchors in place with screw clamps.
- Then suspend the H anchors in the base holes already prepared.
- The required roof pitch of 2% (gradient towards the rear) can be achieved by varying the height of the stud supports.
- The required gradient can also be achieved by shortening the studs.
- After the holes have been filled with C25/30 concrete, the foundation must be allowed to set for at least 3 days.
- The maximum snow load for this carport is 3,0 kN/m<sup>2</sup>, resulting in a maximum permissible snow depth of 1,50 m. If the snow depth exceeds this amount, the roof must be cleared.

## Warranty terms of weka Holzbau GmbH

We guarantee the function of our products for 5 years from the date of delivery based on the following conditions – however only on the wooden parts of our products (hereinafter weka product) and not on connected components or parts of the weka product made of another material besides wood. Within the warranty period defective parts or missing parts of the product or the product itself will be replaced at our discretion. The warranty extends only to the free-of-charge replacement of the respective faulty or defective wooden part. The warranty does not cover any consequential or additional costs, in particular no delivery and installation or modification costs.

The warranty is void in case of:

- failure to follow the assembly instructions,
- changes (additions or modifications) made to the product diverging from the assembly instructions,
- load limits (e.g. snow load, etc.) having been exceeded,
- the weka product having been installed on an incorrect foundation or floor plate, etc., in particular in case of violation of the rules of architecture,
- lack of or insufficient care of the wood (maintenance measures such as preservation or painting of the wood),
- wind speeds stronger than force 7 (moderate gales), natural catastrophes or brute force having caused the damage to the weka product,
- the deficiency consisting in changes which are typical for wood, such as discoloration, formation of cracks, warping, shrinking, swelling or similar normal effects on the material "wood".

Warranty claims must be accompanied by the original packing slip and the original sales receipt and must be submitted within the warranty period in writing or by fax or e-mail. A further prerequisite for a claim is the immediate notification of the defect or damage in the form of pictures and a written description of the defect.

Address all warranty claims to:

weka Holzbau GmbH, Johannesstraße 16, 17034 Neubrandenburg  
Fax: 0395/42908-83; E-mail: info@weka-holzbau.com

## TOOL

You should have the following tools to hand before beginning assembly. (Not supplied.)

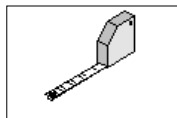

Spring tape measure

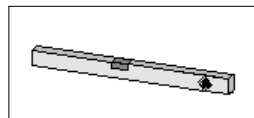

Spirit level

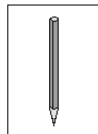

Pencil

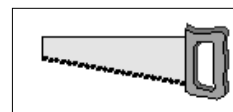

Mitre saw/hand disk saw

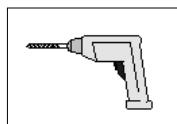

Drill



Electric screwdriver

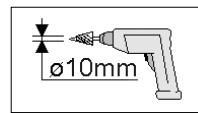

Taper drill

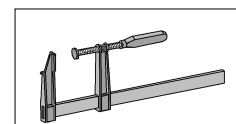

Screw clamp

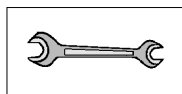

Spanner



Silicone

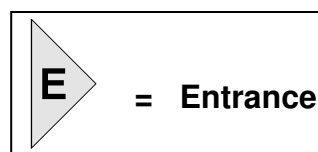

The screw connections should be checked and retightened at regular intervals. This product is manufactured primarily from solid wood and as wood is a natural product, prolonged weathering, in particular after long hot periods, may lead to the formation of dry cracks. These dry cracks are in no way a quality defect but a natural occurrence and, depending on the weather conditions, these cracks may close up again to a minimum.

In addition, these dry cracks which appear along the grain of the wood have no effect on the stability and durability of the material. In other words, the static properties are unaffected.

- fr -

## Chère Cliente, cher Client

Nous vous remercions d'avoir choisi un produit weka.

- Lisez entièrement la présente notice avant de procéder à l'assemblage afin d'éviter les erreurs et les dommages.
- **IMPORTANT !**  
**Veillez vérifier immédiatement, à l'aide de la liste des pièces, si le produit weka est arrivé complet et en bon état.**
- Ne détruisez la liste des pièces qu'une fois la garantie écoulee. Cette liste vous permet de vérifier si les pièces détachées sont complètes et doit être conservée avec le justificatif d'achat. Elle vous permettra de faire valoir aisément d'éventuelles réclamations. Les numéros de pos. de la liste des pièces ne sont pas identiques aux numéros de pos. de la présente notice de montage.
- Nous vous recommandons d'effectuer le montage à 2 personnes.
- Afin de prévenir tout accident, éviter la présence d'enfants à proximité durant le montage.
- Nous nous réservons le droit d'apporter aux produits des modifications dans le cadre de l'évolution technique. De légères différences sont par conséquent possibles par rapport aux illustrations.
- Ne pas jeter simplement le matériel d'emballage! Les emballages en papier, carton et carton ondulé doivent être déposés dans le container de tri correspondant.

## RECOMMANDATIONS

- Pré-percez tous les assemblages vissés afin d'éviter d'endommager les éléments en bois! Ceci vous est rappelé par le symbole suivant dans la notice:



- Evitez d'exposer le bois au soleil ou à l'humidité pendant des heures.
- Le bois est un produit naturel. Les différentes colorations, les nœuds et les fissures sont normaux et n'ont aucun effet sur la tenue statique.
- Le montage en respect des règles de la statique exige d'ancrer les poteaux à l'aide de supports en H dans des fondations en béton. Les supports de poteaux sont disponibles à titre d'accessoires weka contre supplément.
- **Le plan de fondation vous sera remis par votre revendeur!**
- Pour faciliter l'alignement précis des éléments d'ancrage en H, repérez les distances nécessaires entre les poteaux sur une latte repère et fixez-y les éléments d'ancrage à l'aide de serre-joints.
- Suspendez ensuite les éléments d'ancrage en H dans les trous préalablement aménagés de la fondation.
- Pour obtenir la pente requise du toit de 2% (inclinaison vers l'arrière), variez la hauteur des supports de poteaux. La pente requise peut également être obtenue en raccourcissant les poteaux.
- Après avoir rempli les trous de béton C25/30, laissez durcir les fondations pendant au moins 3 jours.
- Ce carport peut supporter une charge de neige maximale de 3,0 kN/m<sup>2</sup>, ceci correspond à une hauteur de neige maximale autorisée de 1,50 m. A partir de cette hauteur de neige, le toit doit être dégagé.

## Conditions de garantie de la weka Holzbau GmbH

Nous vous accordons, aux conditions qui suivent, 5 ans de garantie à compter de la date de livraison sur le bon fonctionnement des pièces en bois de nos produits exclusivement (désignés produits weka), à l'exclusion des pièces qui leur sont associées et à l'exclusion des composants du produit weka fabriqués en un matériau autre que le bois. Pendant la durée de la garantie, les pièces défectueuses, ou les pièces de la marchandise manquantes ou la marchandise elle-même seront remplacées suivant notre choix. L'étendue de la garantie se limite au remplacement gratuit de la pièce en bois défectueuse ou comportant un vice. Sont

exclus de l'étendue de la garantie les coûts consécutifs ou supplémentaires et singulièrement les coûts de livraison, de montage ou de transformation.

La garantie est exclue dans les cas suivants :

- La notice de montage n'a pas été respectée,
- Le produit a été modifié (par des pièces rapportées ou des transformations) par rapport à ce qui est dit dans la notice de montage,
- Les limites de charge indiquées (par exemple le poids de la neige etc) ont été dépassées,
- Le produit weka a été monté sur des mauvaises fondations (dalle, plancher ou autre) et notamment en cas de non respect des règles de construction,
- L'entretien du bois a été négligé ou est insuffisant (entretien : protection du bois, peinture, etc.).
- Le vent de force supérieure à 7, les catastrophes naturelles ou des manifestations de violence ont endommagé le produit weka.
- Le défaut consiste en des modifications inhérentes à la nature du matériau « bois », comme par exemple les changements de couleur caractéristiques pour le bois, les fissures, le gauchissement, le rétrécissement, ou le gonflement ou autres.

Le recours à la garantie ne peut se faire qu'avec le bordereau de colisage d'origine et le document d'achat d'origine pendant la période de garantie par écrit, par fax ou par courriel. Il est subordonné à la dénonciation immédiate du vice ou du défaut sous forme d'une description explicite du dommage par le texte et l'image.

Le recours à la garantie sera adressé à :

weka Holzbau GmbH, Johannesstrasse 16, 17034 Neubrandenburg  
Télécopie : 0395/42908-83; e-Mail : info@weka-holzbau.com

## OUTIL

Pour le montage, nous vous recommandons de préparer les outils suivants.  
(N'est pas compris dans la fourniture!)

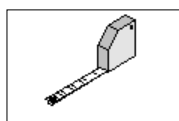

Décimètre à ruban

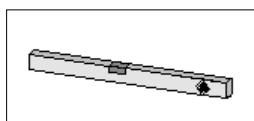

Niveau à bulle

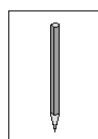

Crayon

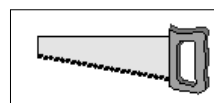

Scie à denture fine

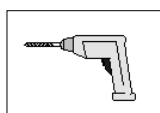

Perceuse

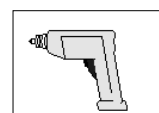

visseuse électrique

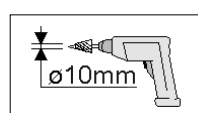

alésoir conique

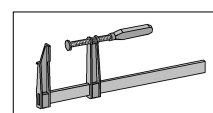

serre-joint

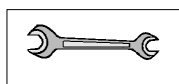

Clé

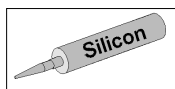

silicone

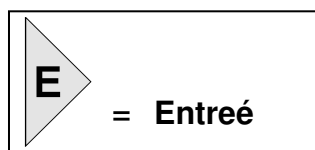

Il est conseillé de vérifier et de resserrer les assemblages vissés à intervalles réguliers. Ce produit est essentiellement fabriqué en bois massif. Le bois étant un matériau naturel, il se peut que des conditions climatiques extrêmes, notamment après de longues périodes de chaleur, entraînent la formation de fentes de sécheresse. Ces fentes de sécheresse ne constituent en aucun cas un défaut de qualité, mais un phénomène naturel. Selon la situation météorologique, ces fentes peuvent se refermer quasi-intégralement. De plus, ces fentes de sécheresse, qui apparaissent dans le bois dans le sens de la longueur, n'exercent aucune influence sur la solidité et la résistance du matériau. Autrement dit, les propriétés statiques ne sont pas affectées.



- it -

**Egredi clienti,  
ci congratuliamo con voi per avere scelto un prodotto weka.**

- Prima del montaggio leggete con cura le presenti istruzioni al fine di evitare errori di montaggio o danni.
- **IMPORTANTE !**  
**Controllate subito con l'ausilio della lista di imballaggio che il prodotto weka sia stato fornito completo e senza danni.**
- Vi preghiamo di conservare la lista di imballaggio solo alla scadenza del periodo di garanzia. Questa lista serve per controllare la completezza della fornitura e deve essere conservata insieme allo scontrino. Con l'ausilio della lista è possibile risolvere eventuali reclami. I numeri di posizione della lista di imballaggio non corrispondono con i numeri di posizione delle seguenti istruzioni di montaggio.
- Raccomandiamo di eseguire il montaggio in 2 persone.
- Per scongiurare eventuali incidenti tenere lontano i bambini dal luogo di montaggio
- Ci riserviamo di apportare modifiche ai fini del progresso tecnologico. Per tale motivo è possibile che nelle rappresentazioni vengano a crearsi lievi differenze.
- Non gettare via il materiale di imballaggio! La carta, il cartone normale e ondulato cosiccome gli imballaggi in plastica devono essere smaltiti negli appositi contenitori di raccolta.

## **RACCOMANDAZIONI**

- Per evitare danni agli elementi in legno si raccomanda di preforare tutti i punti di avvitaggio a vite! Il presente simbolo richiama la vostra attenzione su tale particolare nel corso delle istruzioni:



- Proteggete il legno dall'irradiazione solare diretta e dall'umidità prolungate.
- Il legno è un prodotto naturale. Differenti irregolarità cromatiche, la ramificazione e la crepatura sono da considerarsi normali e non hanno alcuna influenza sulla statica.
- Per un corretto montaggio statico è necessario ancorare i montanti nelle fondamenta in calcestruzzo con supporti ad H. I supporti dei montanti sono disponibili come accessorio weka su sovrapprezzo.
- **Per uno schema delle fondamenta rivolgetevi al vostro rivenditore specializzato!**
- Per facilitare l'allineamento dell'elemento di ancoraggio ad H contrassegnate le necessarie distanze fra i montanti con un regolo e fissate in tali punti gli elementi di ancoraggio per mezzo di morsetti.
- Successivamente inserite gli elementi di ancoraggio ad H nei pozzetti di fondamenta creati in precedenza.
- L'inclinazione del tetto necessaria (2% verso il retro) può essere raggiunta variando l'altezza del supporto del montante. L'inclinazione necessaria può essere raggiunta anche alternativamente accorciando i montanti.
- Dopo aver riempito i pozzetti con calcestruzzo C25/30, le fondamenta devono asciugare per almeno 3 giorni.
- Il carico di neve massimo per questa copertura per posto auto è di 3,0 kN/m<sup>2</sup>, ne risulta un'altezza massima di neve consentita di 1,50 m. Il tetto deve essere liberato a partire da questa altezza.

## **Condizioni di garanzia di weka Holzbau GmbH**

Concediamo alle seguenti condizioni – tuttavia soltanto sulle parti in legno dei nostri prodotti (qui di seguito designate prodotto weka), non sui componenti o gli elementi del prodotto weka a queste collegati – una garanzia di funzionalità di 5 anni dalla data di consegna. Per tutta la durata della garanzia sostituiamo, a nostra discrezione, le parti difettose o mancanti della merce o la merce stessa. La portata della garanzia comprende esclusivamente la sostituzione gratuita della parte in legno guasta o difettosa. La garanzia non copre invece i costi conseguenti o aggiuntivi, in particolare le spese di consegna, installazione e modifica.

La garanzia è esclusa se:

- non ci si è attenuti alle istruzioni per il montaggio,
- sono state apportate modifiche (aggiunte o cambiamenti) al prodotto rispetto alle istruzioni per il montaggio,
- sono stati superati i limiti di sollecitazione indicati (ad es. carico da neve ecc.),
- le fondazioni del prodotto weka sono state realizzate in maniera non corretta (fondamenta / piastra base o similare), in particolare se sono state violate le regole dell'architettura,
- il legno non è stato curato o è stato curato in misura insufficiente (manutenzione: protettivo o vernice per legno ecc.),
- velocità del vento superiori a forza 7, catastrofi naturali o azioni violente che hanno causato il danno al prodotto weka,
- il difetto consiste in alterazioni cromatiche, crepe, imbarcamenti, ritiri, rigonfiamenti o simili modificazioni che sono normali, in quanto legate alla natura del materiale „legno“.

I diritti di garanzia possono essere fatti valere soltanto unitamente alla distinta di imballo originale e al giustificativo d'acquisto originale e devono essere rivendicati per iscritto oppure mediante fax o e-mail entro la durata della garanzia. Premessa per la rivendicazione è la tempestiva segnalazione del difetto o del danno sotto forma di rappresentazione ordinata dello stesso tramite testo e figure.

Le richieste di garanzia devono essere rivolte a:

weka Holzbau GmbH, Johannesstraße 16, 17034 Neubrandenburg  
 Fax: 0395/42908-83; e-mail: info@weka-holzbau.com

## UTENSILE

Prima di iniziare con il montaggio tenere a portata di mano i seguenti utensili.  
 (Non compreso nella fornitura!)

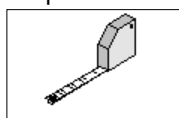

metro a nastro

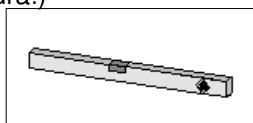

livella ad acqua

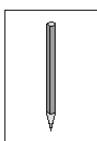

Matita

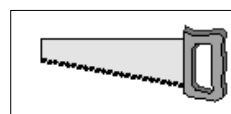

sega fine

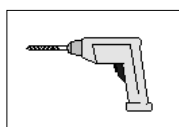

trapano

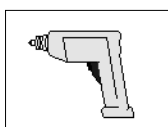

avvitatore elettrico

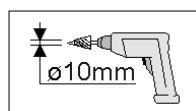

trapano conico

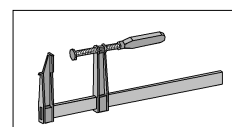

morsetto

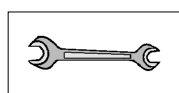

chiave

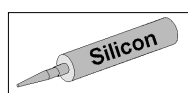



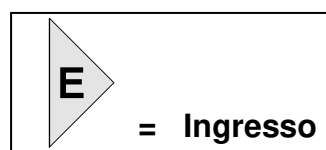

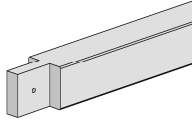
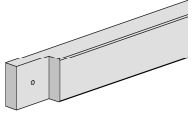
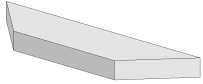
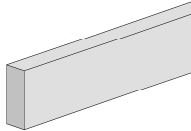
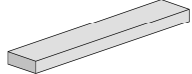
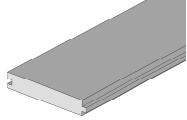
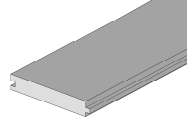
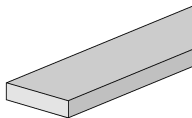

silicone

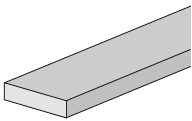
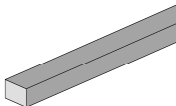
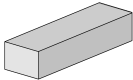
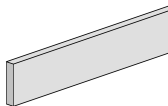
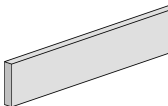
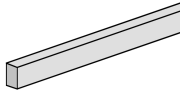
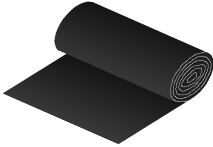
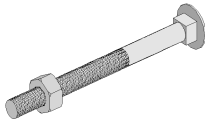

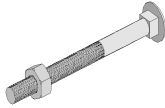
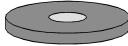

Si raccomanda di controllare periodicamente tutti i collegamenti a vite e di riserrarli all'occorrenza. Questo prodotto è prevalentemente realizzato con legno massiccio e poiché nel materiale legno si tratta di un prodotto naturale, in seguito a condizioni atmosferiche estreme, in particolare durante i lunghi periodi estivi, non è da escludere una formazione di fessure di essiccamento. Queste fessure di essiccamento non sono in nessun caso un difetto di qualità, bensì un fenomeno naturale. A seconda delle condizioni atmosferiche queste fessure possono di nuovo chiudersi, lasciando soltanto uno spiraglio minimo. Inoltre, queste fessure di essiccamento, che si formano in senso longitudinale sul legno, non hanno alcun influsso sulla stabilità e sul carico del materiale. Ciò significa che non vengono in alcun modo pregiudicate le caratteristiche statiche.

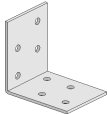
Pos	Bild	Abmessung [mm]	Stück
1		120 / 120 / 2150	8
2		60 / 120 / 3050	8
3		40 / 120 / 700	20
4		80 / 200 / 3140	9
5		40 / 120 / 660	8
6		19,5 / 121 / 3080	29
7		19,5 / 121 / 2944	29
8		20 / 120 / 3000	4

Pos	Bild	Abmessung [mm]	Stück
9		20 / 120 / 3200	8
10		40 / 60 / 3000	1
11		40 / 60 / 200	20
12		18,5 / 90 / 1500	2
13		18,5 / 90 / 2120	8
14		20 / 30 / 1000	10
15		10 m <sup>2</sup>	3
16		M10 x 180	8

Pos	Bild	Abmessung [mm]	Stück
17		M10 x 80	4
18		13,5 / 44 / 4	12
19		5,0 x 35	520
20		2,2 x 55	800
21		2,0 x 16	1200
22		50 / 50 / 40	64
23		5,0 x 120	50
24		5,0 x 100	80

Pos	Bild	Abmessung [mm]	Stück
25		4,5 x 70	75
26		4,0 x 40	320
27		6,0 x 150	8

**GRUNDRISS:**

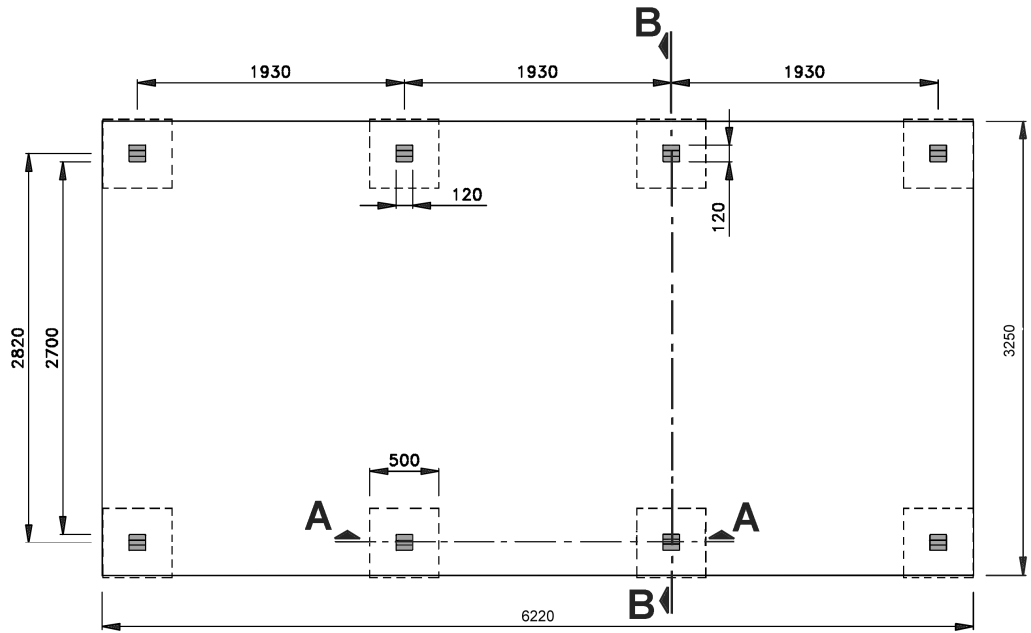

**ANSICHTEN:**

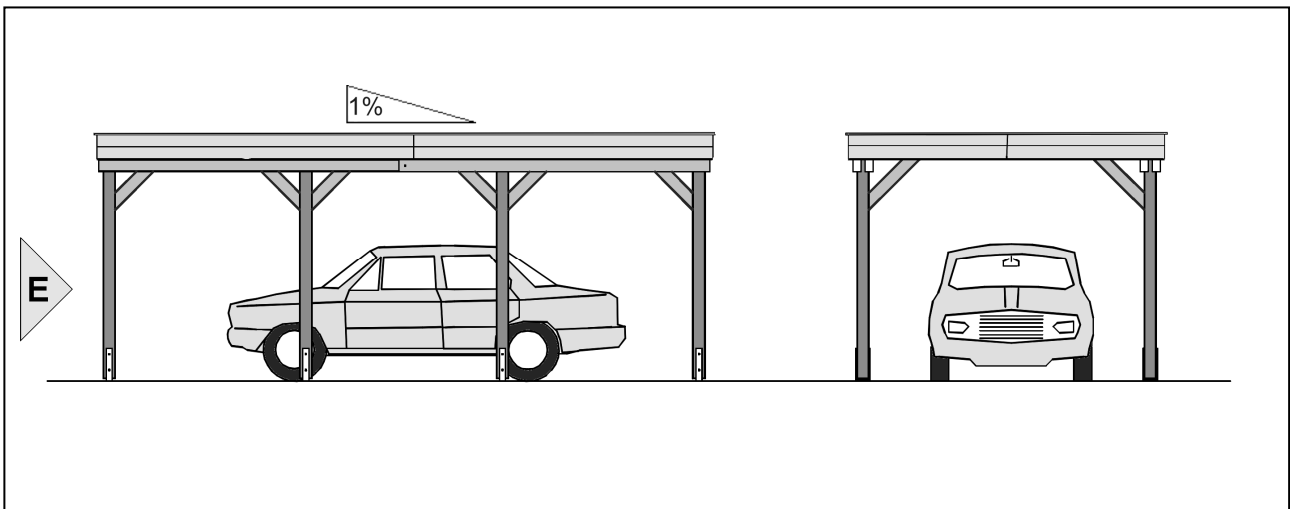

**SCHNITTE:**

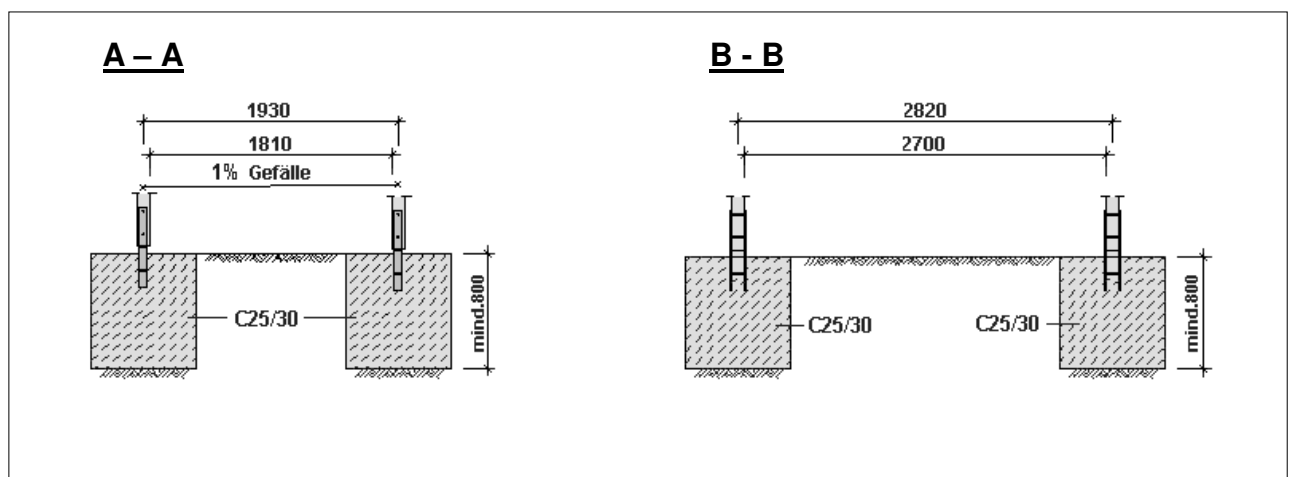

de	H-Anker
en	H anchor
fr	ancrage en H
it	Ancoraggi a H

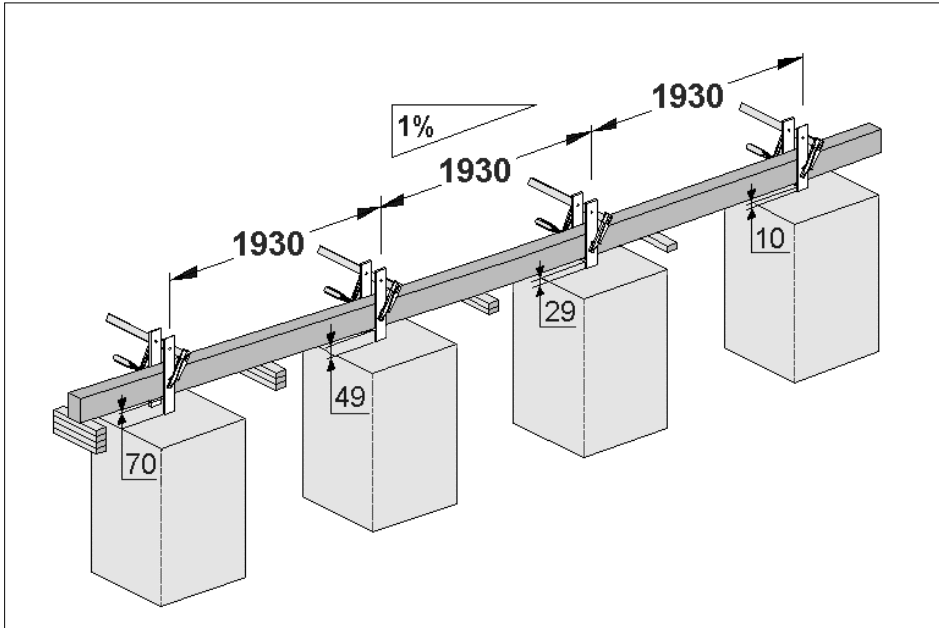
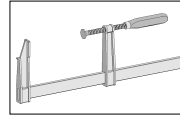
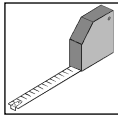
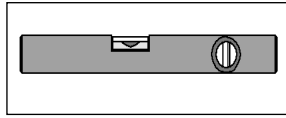

de	Pfosten
en	Stud
fr	poteau
it	montante

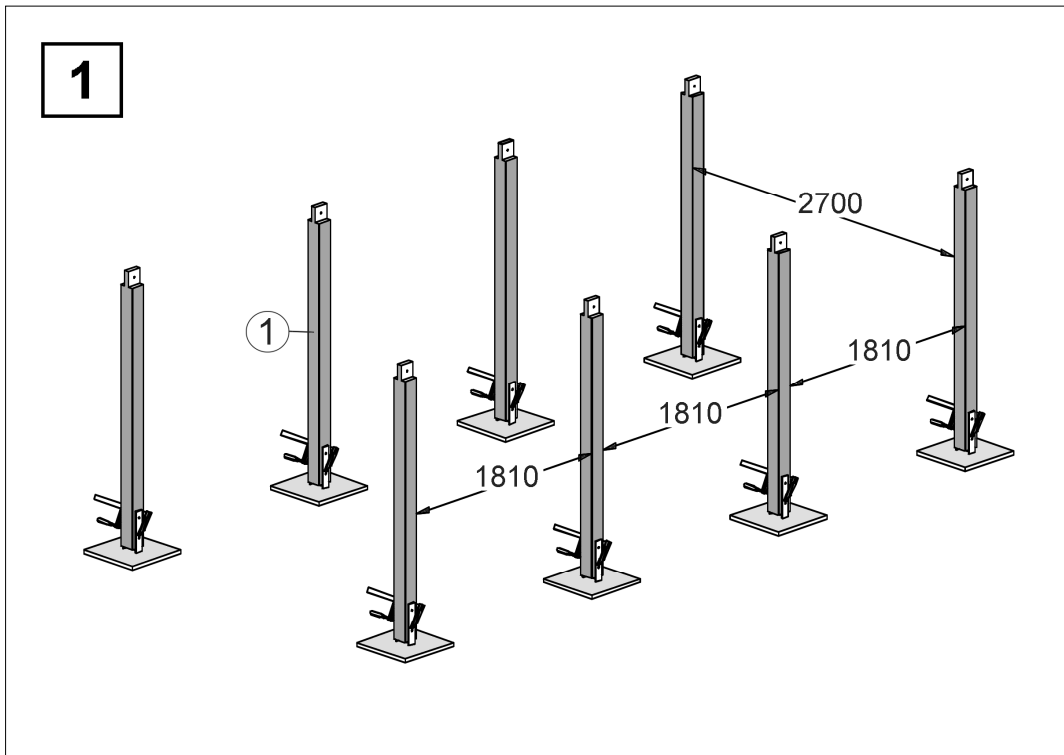
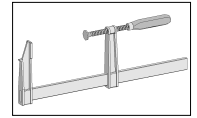
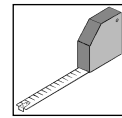
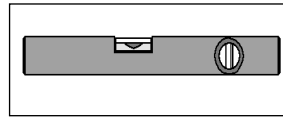



de	Pfette
en	Purlin
fr	panne
it	arcareccio

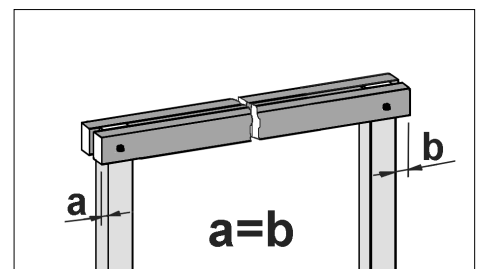
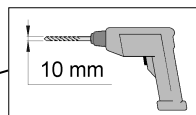
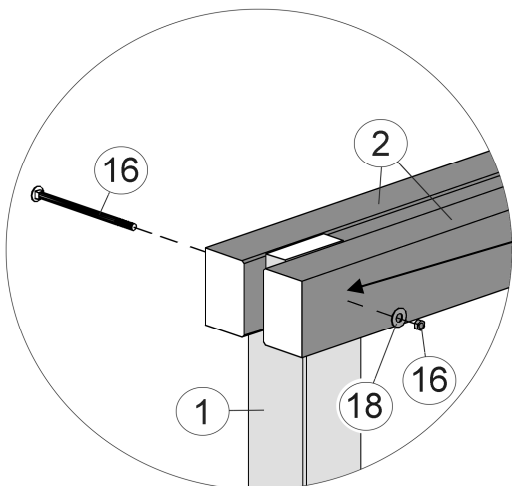
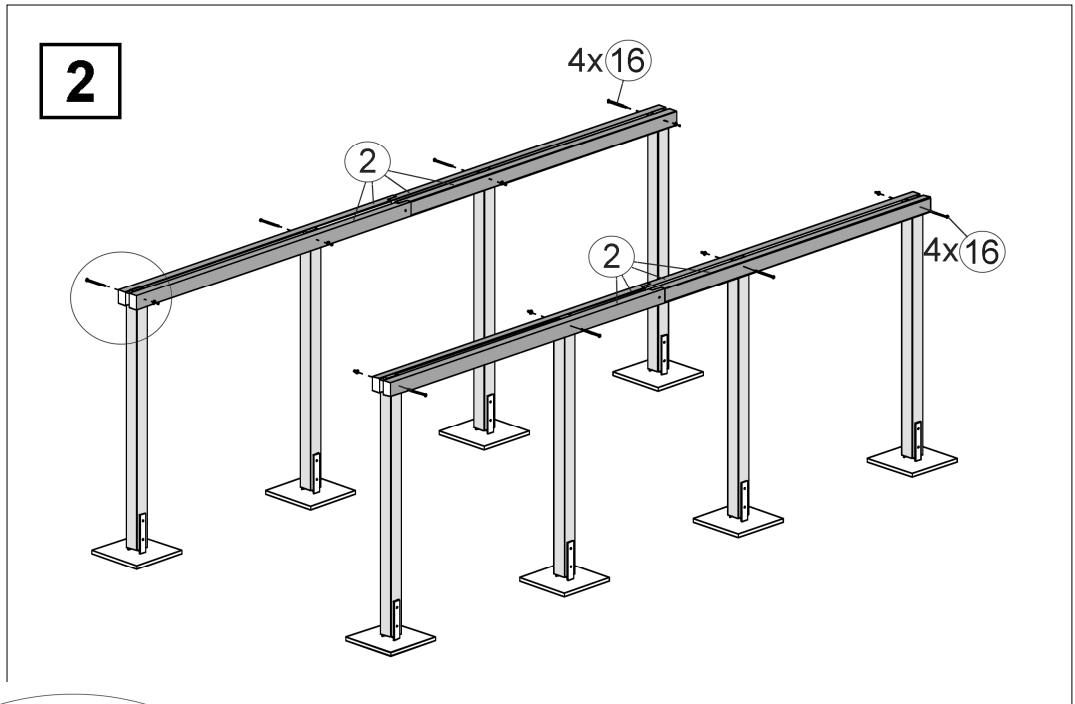
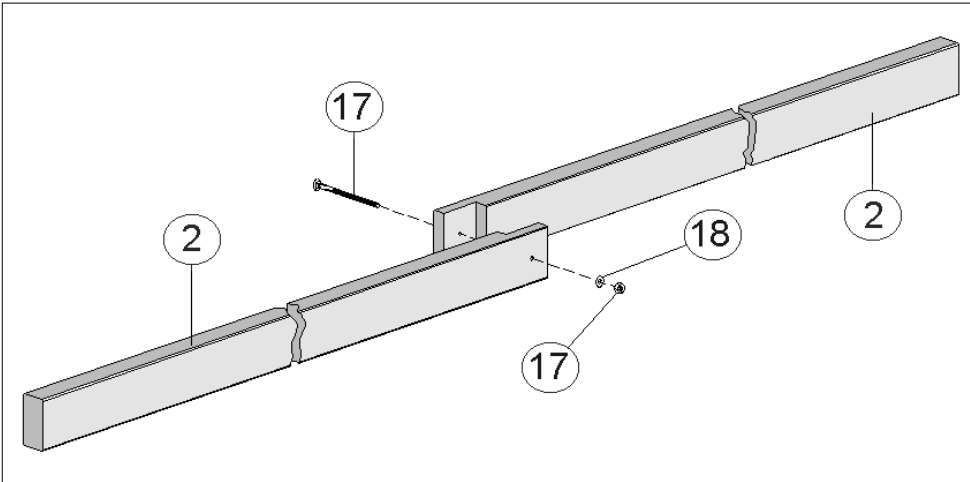
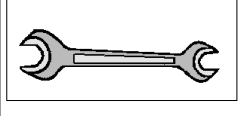
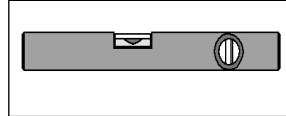
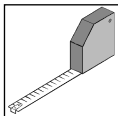
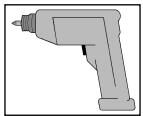
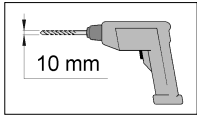

de	Sparren
en	Rafter
fr	chevron
it	travetto

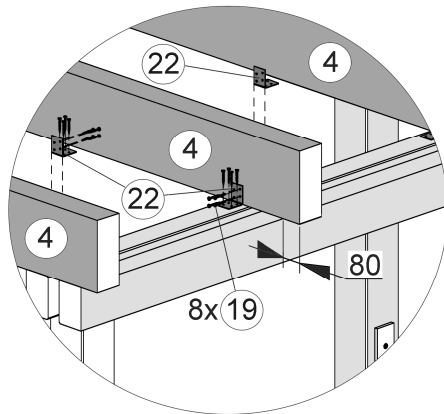
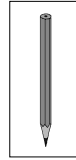
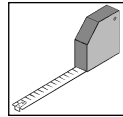
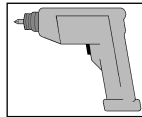
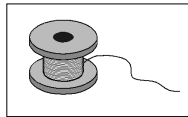

**3**

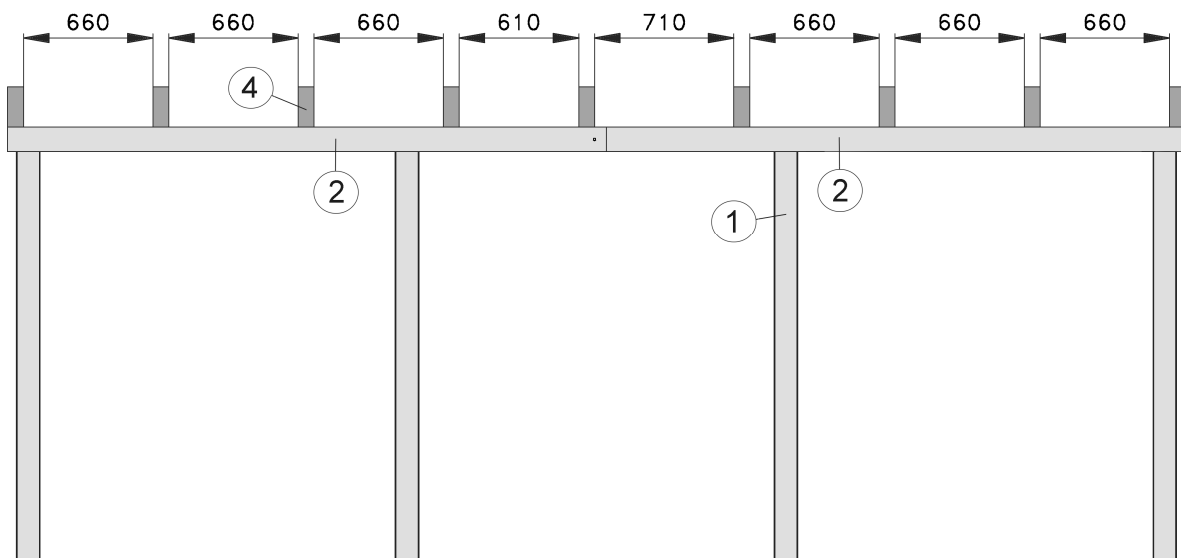
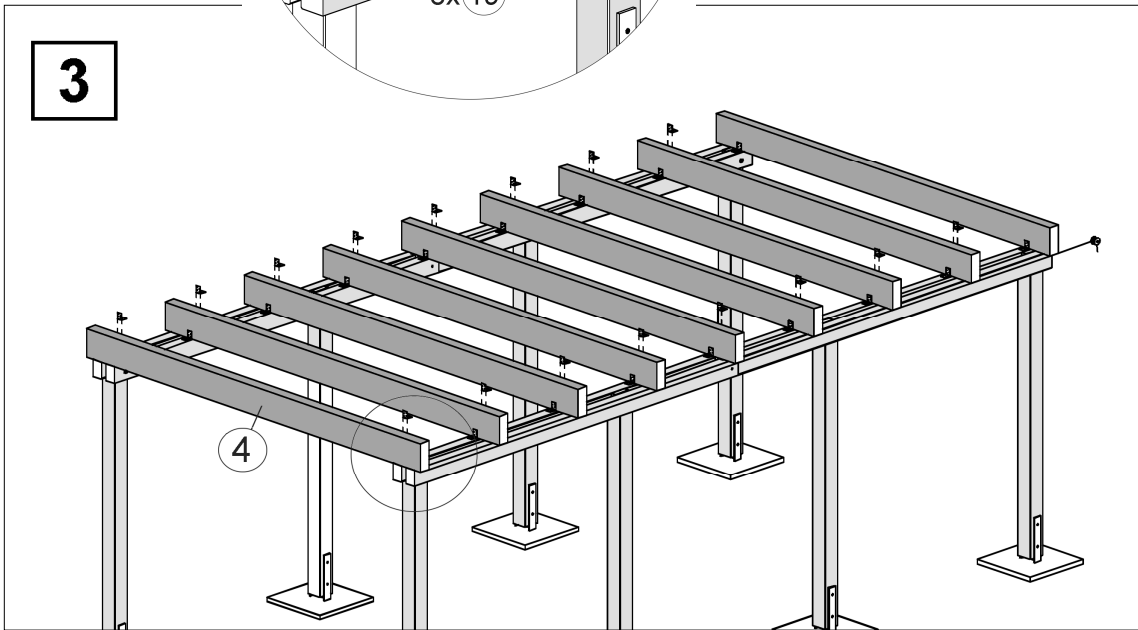

de	Kopfband	Wechsel
en	Strut	Tension slat
fr	bande de tête	Solive d'enchevêtreure
it	nastro terminale	Trave di supporto

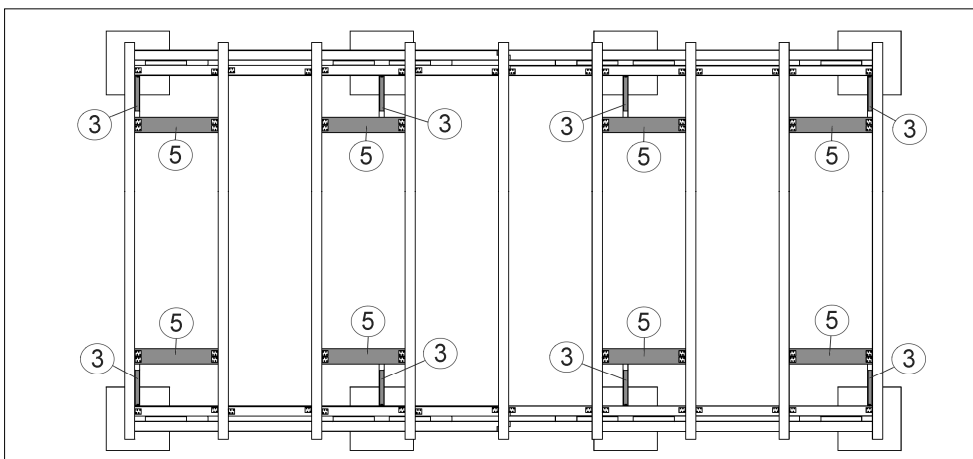
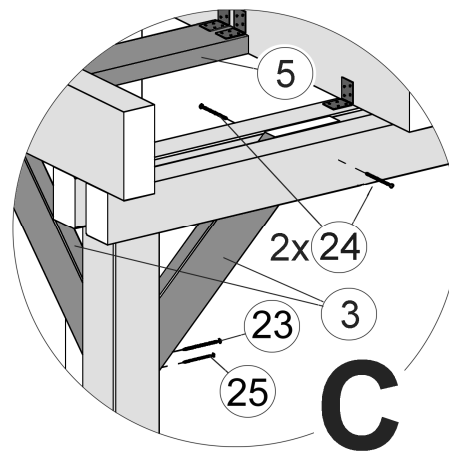
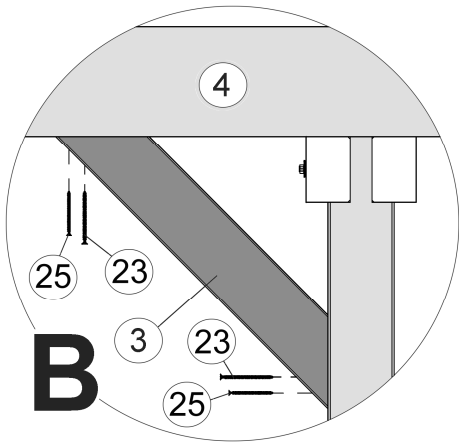
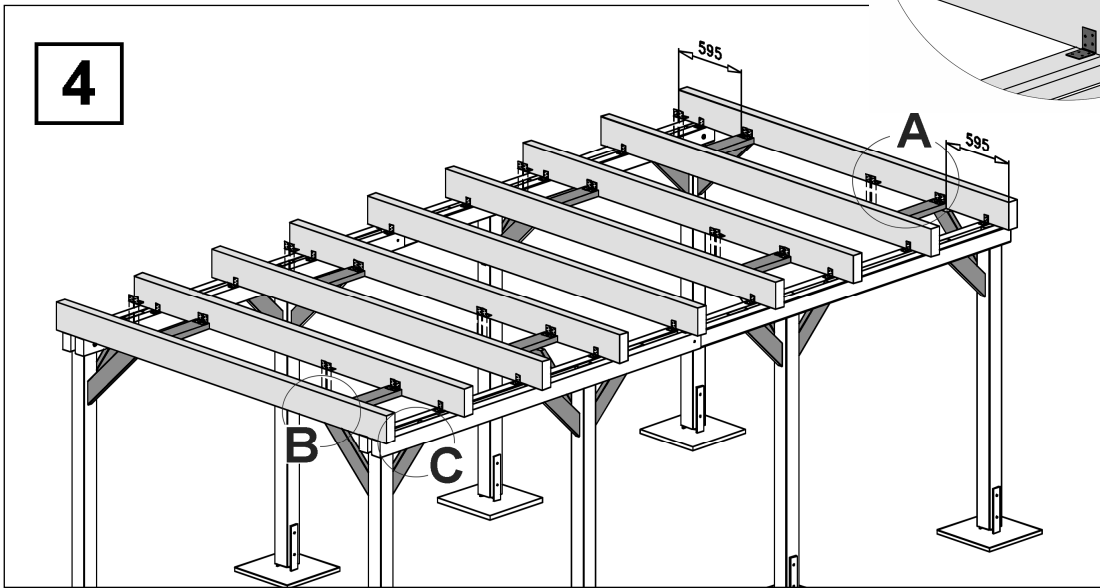
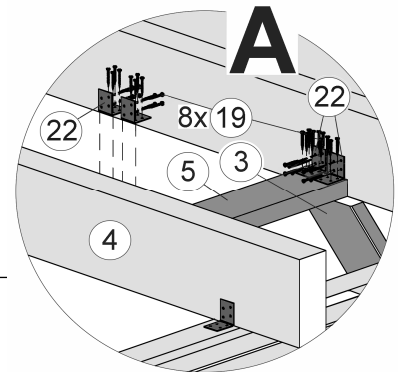
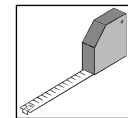
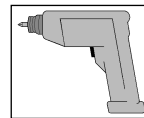
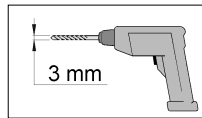

de	Blendenhalter
en	Cover holder
fr	support de cache
it	supporto pannello di copertura

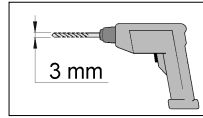
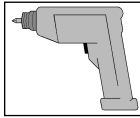

**5**

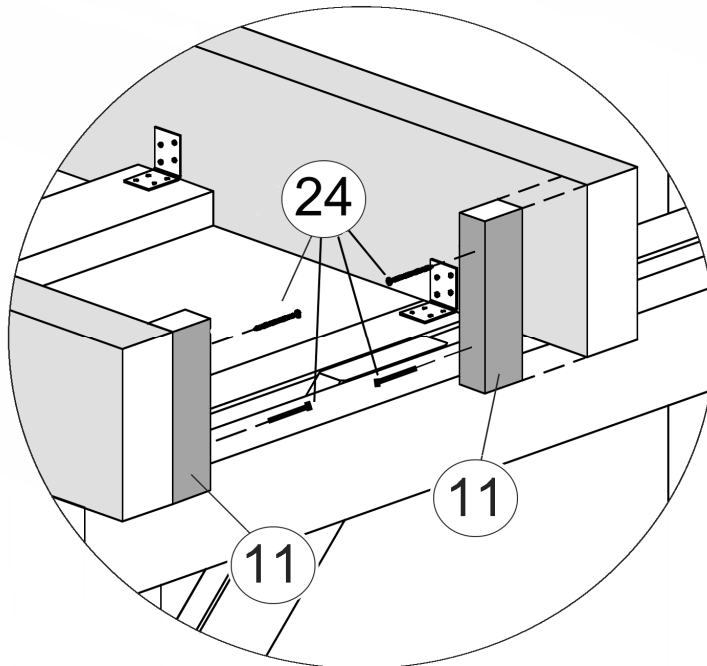
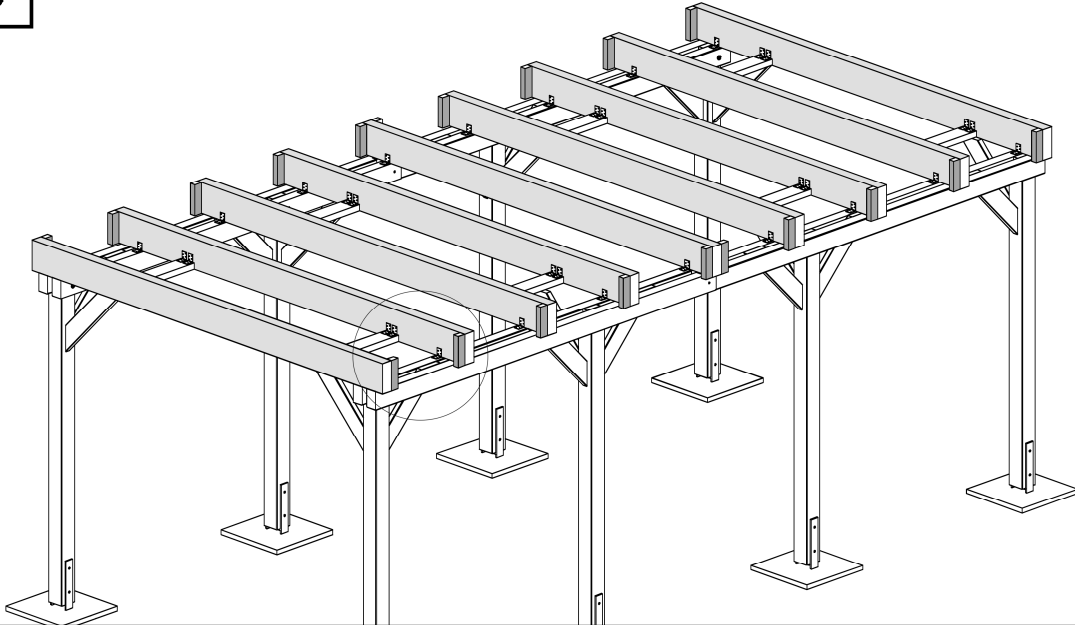

de	Dachrinne	Nicht im Lieferumfang enthalten
en	Gutter	not included in the scope of this delivery
fr	gouttière	n'est pas fournie
it	grondaia	non sono compresi nella fornitura

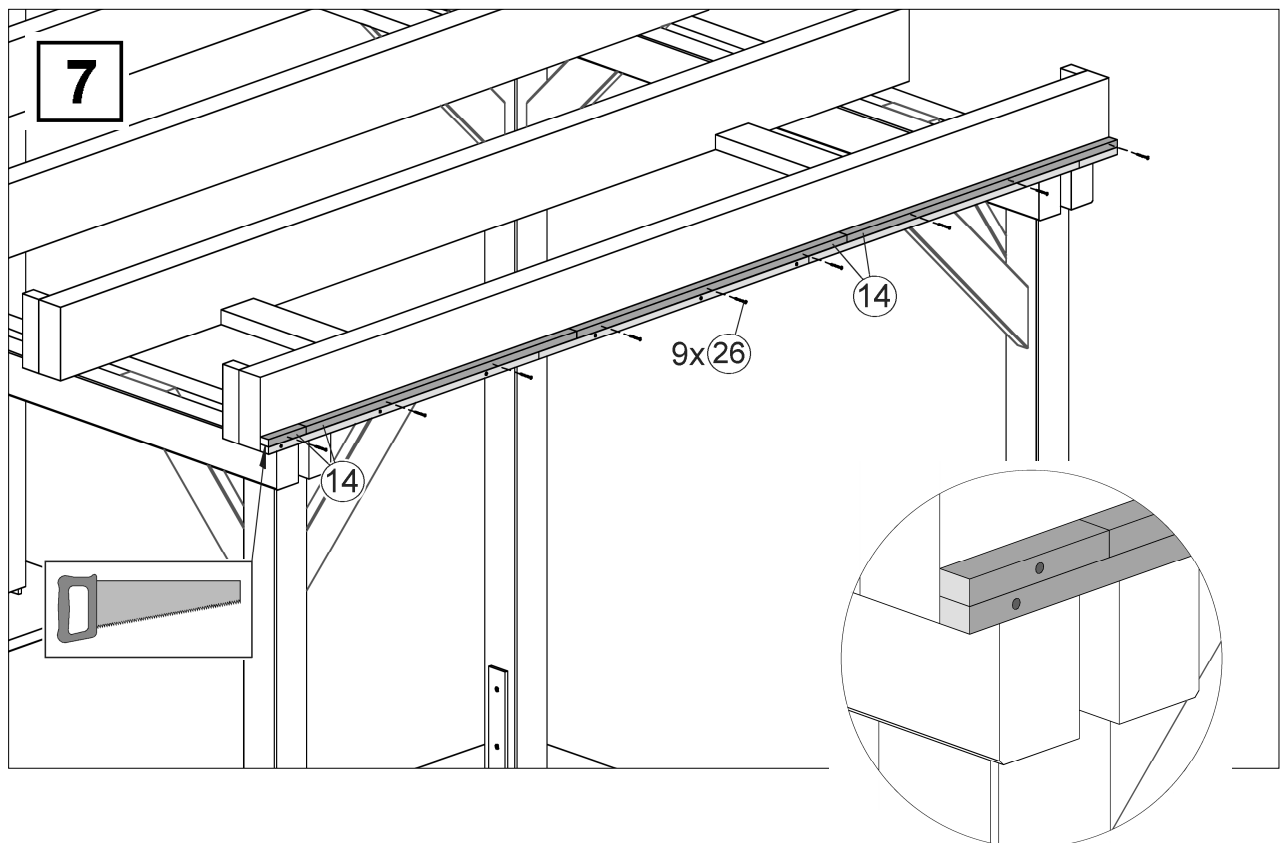
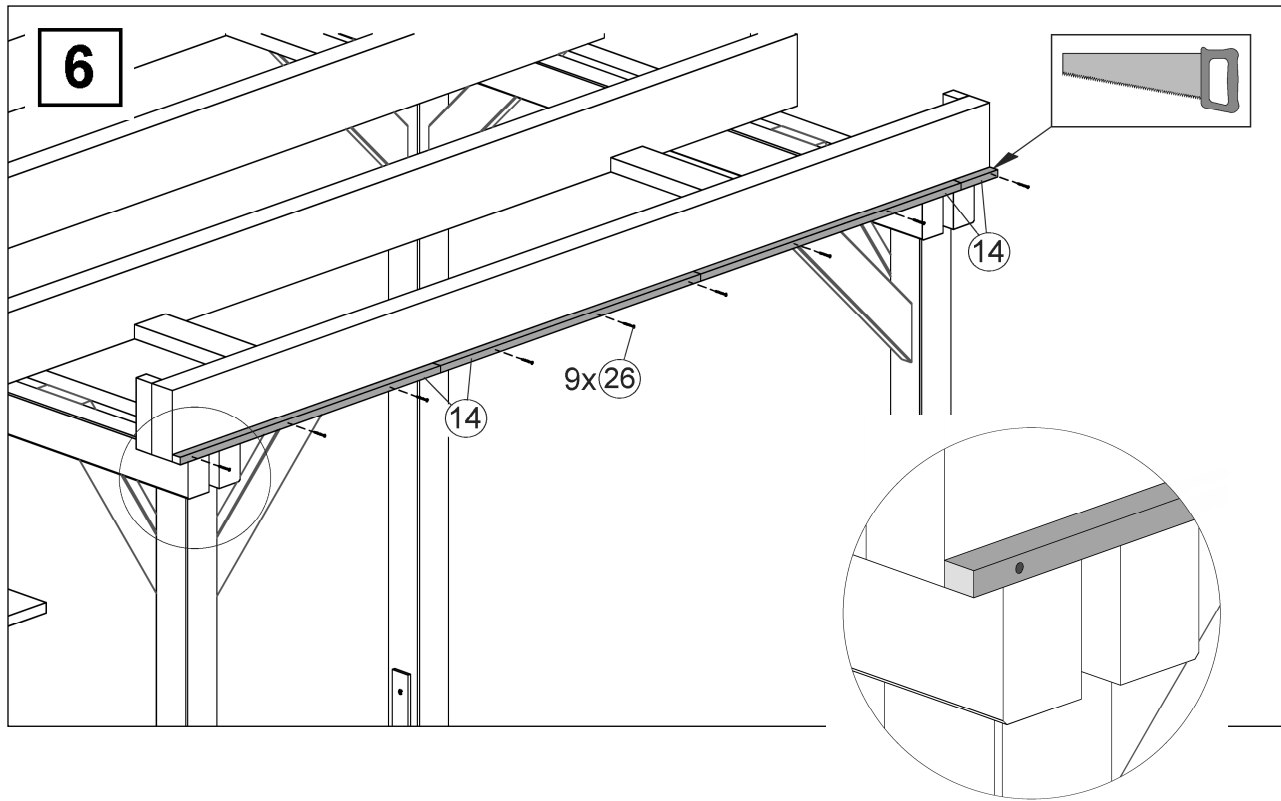
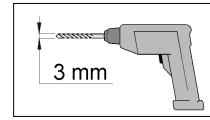
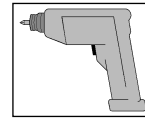

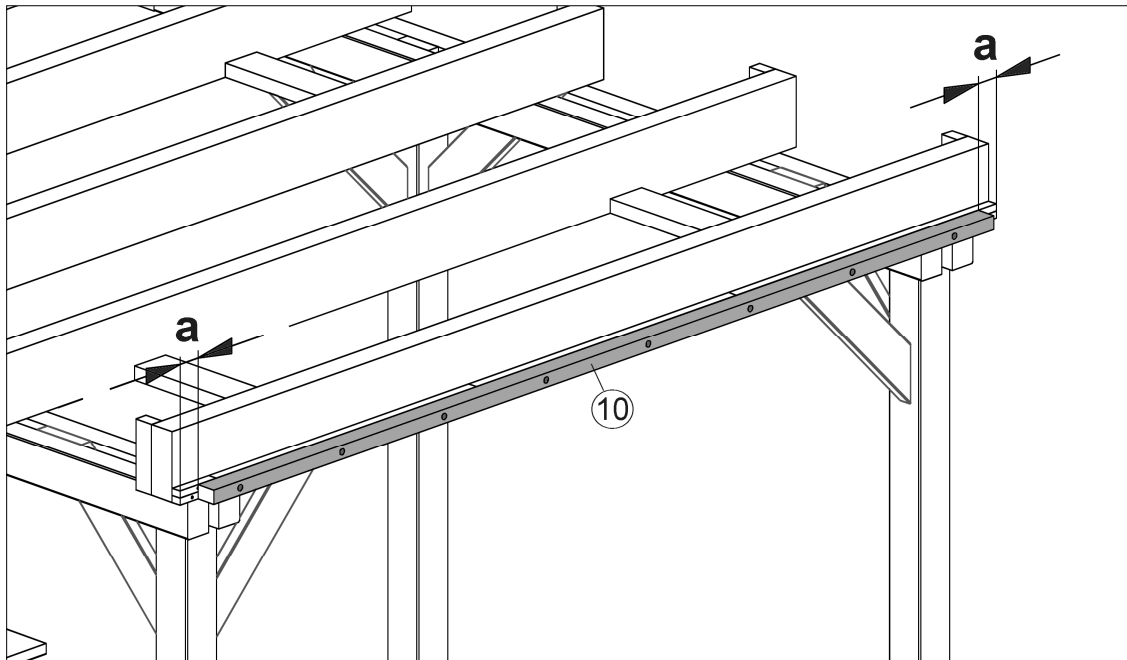
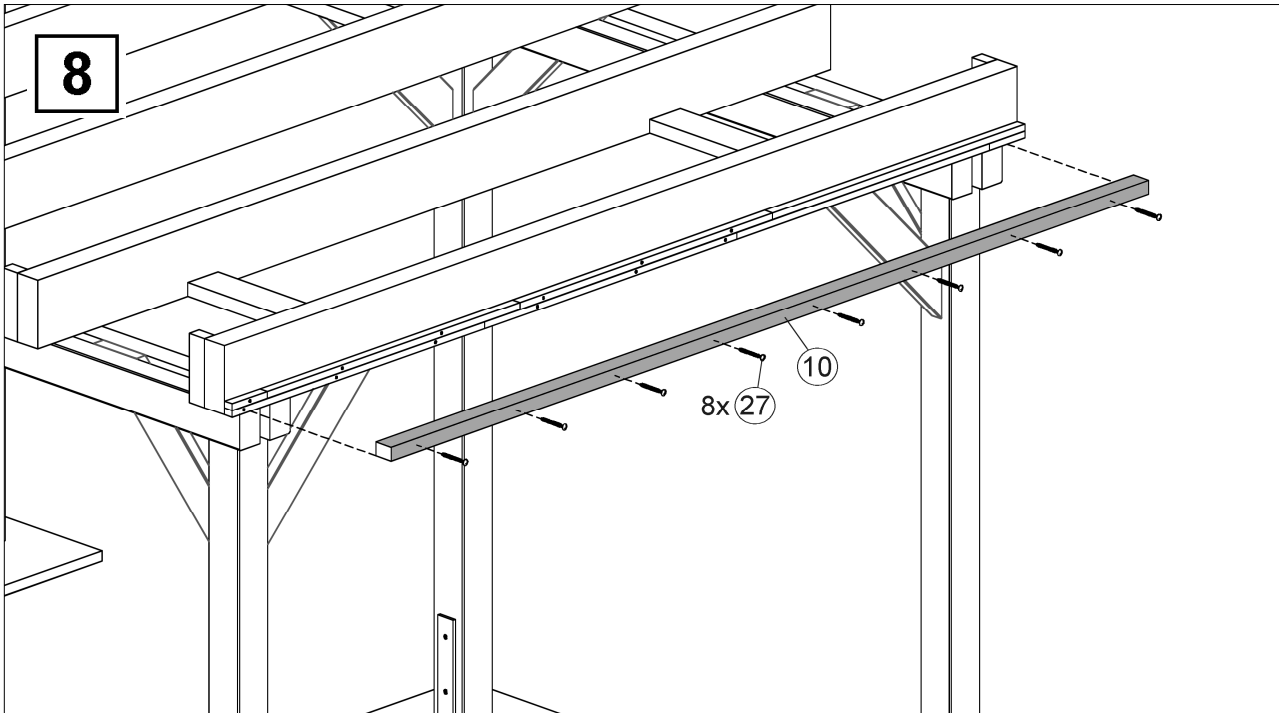
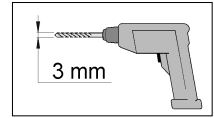
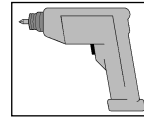

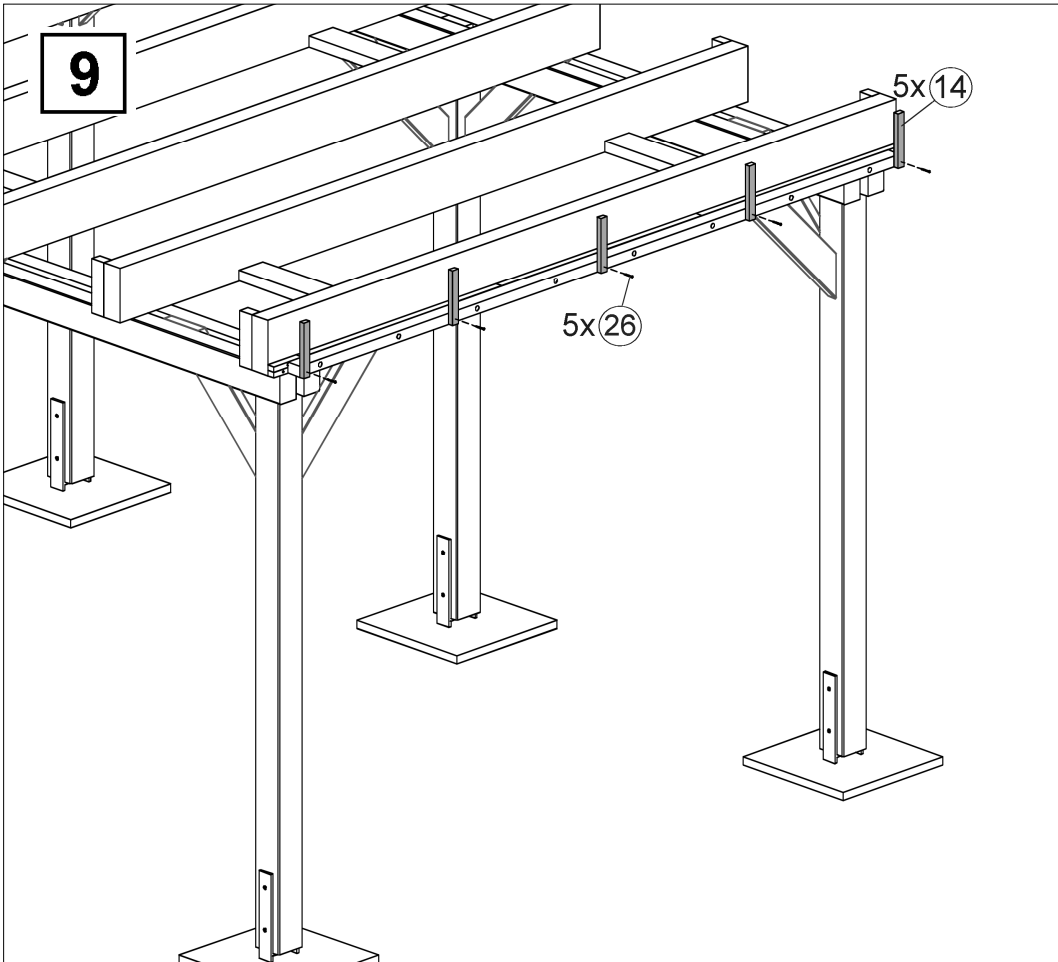
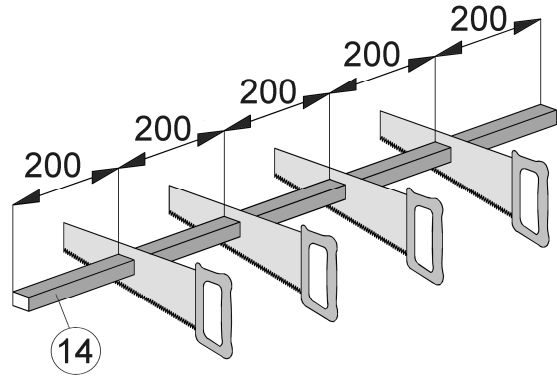
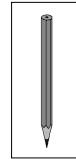
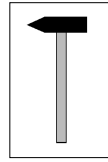
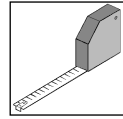
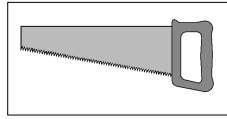
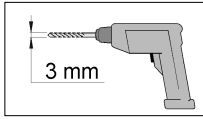
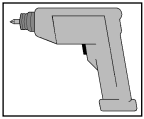

de	Dachschalung
en	Roof boarding
fr	sous-toiture
it	armatura del tetto

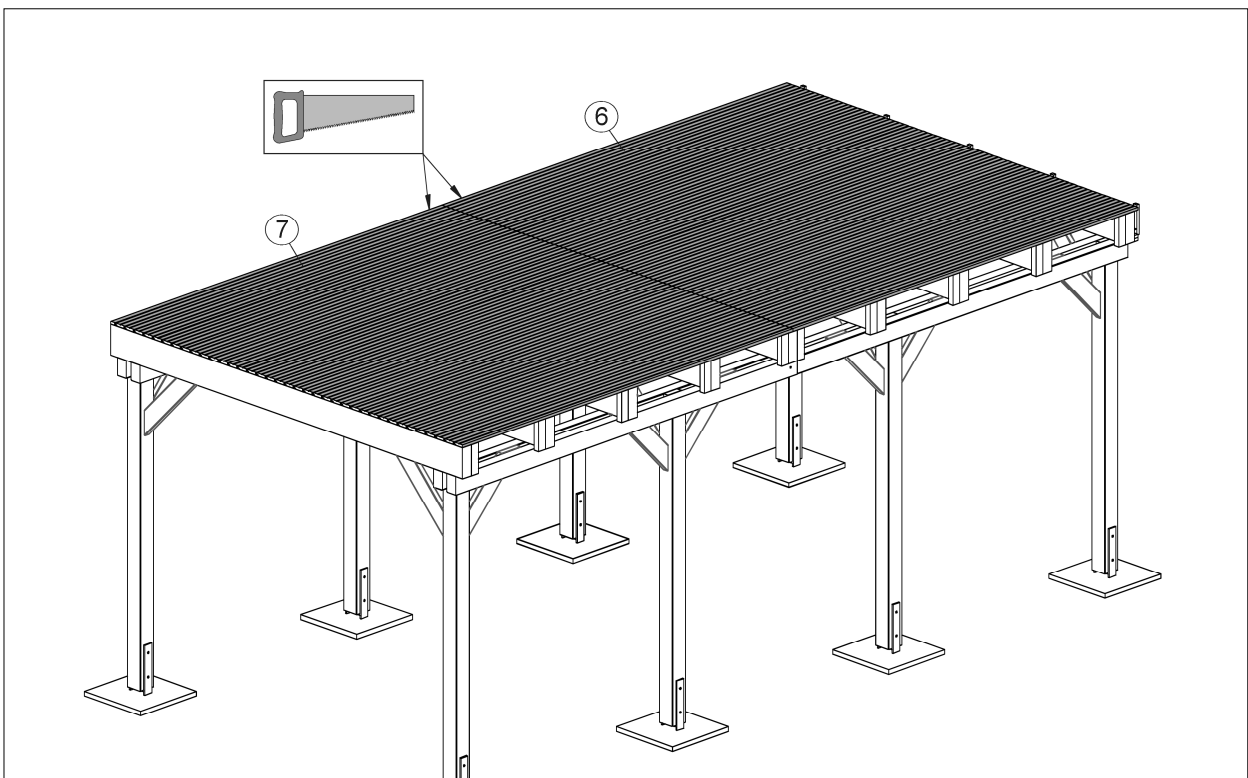
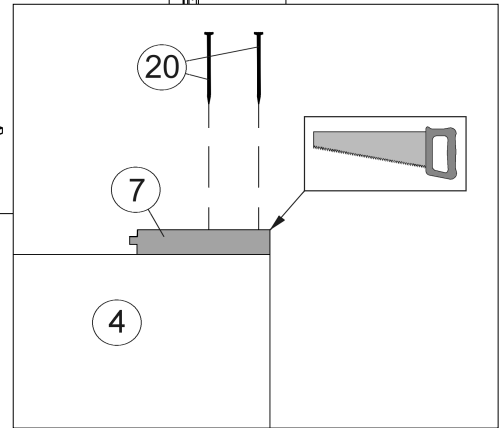
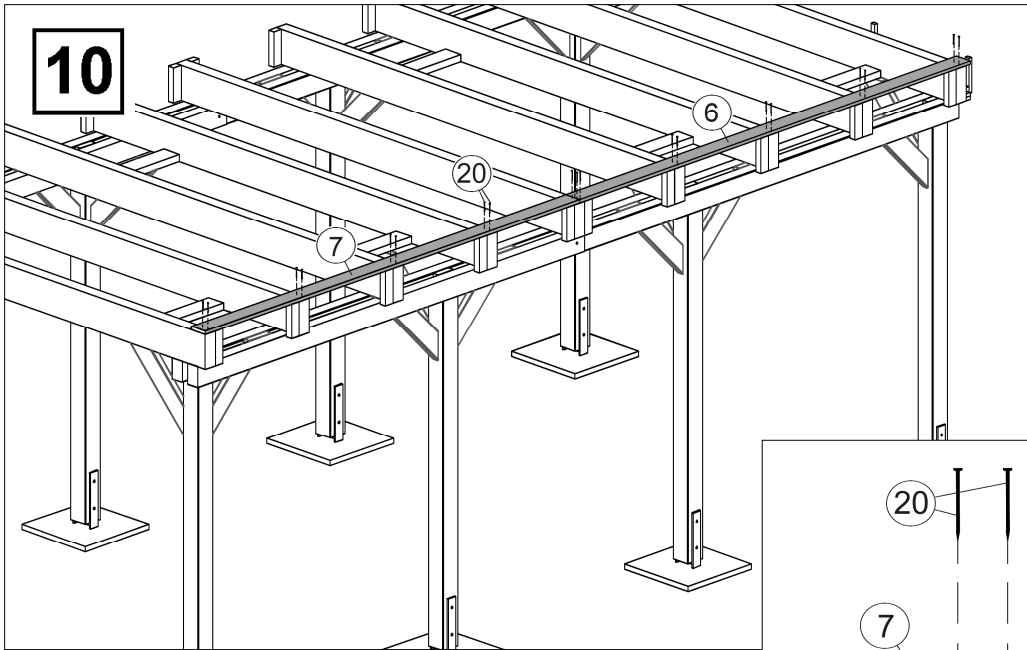
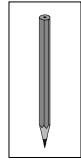
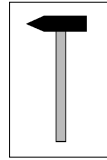
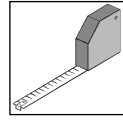
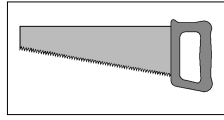



de	Dachpappe
en	Roof paper
fr	carton bitumé
it	cartone catramato

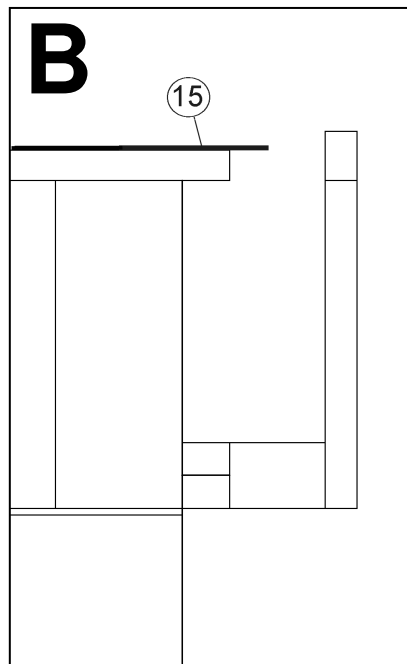
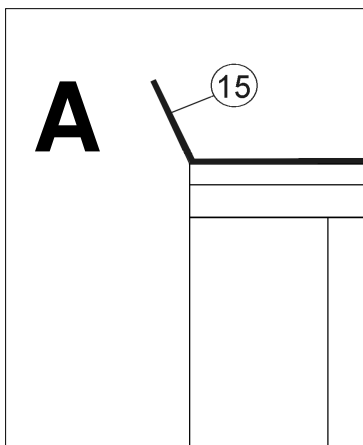
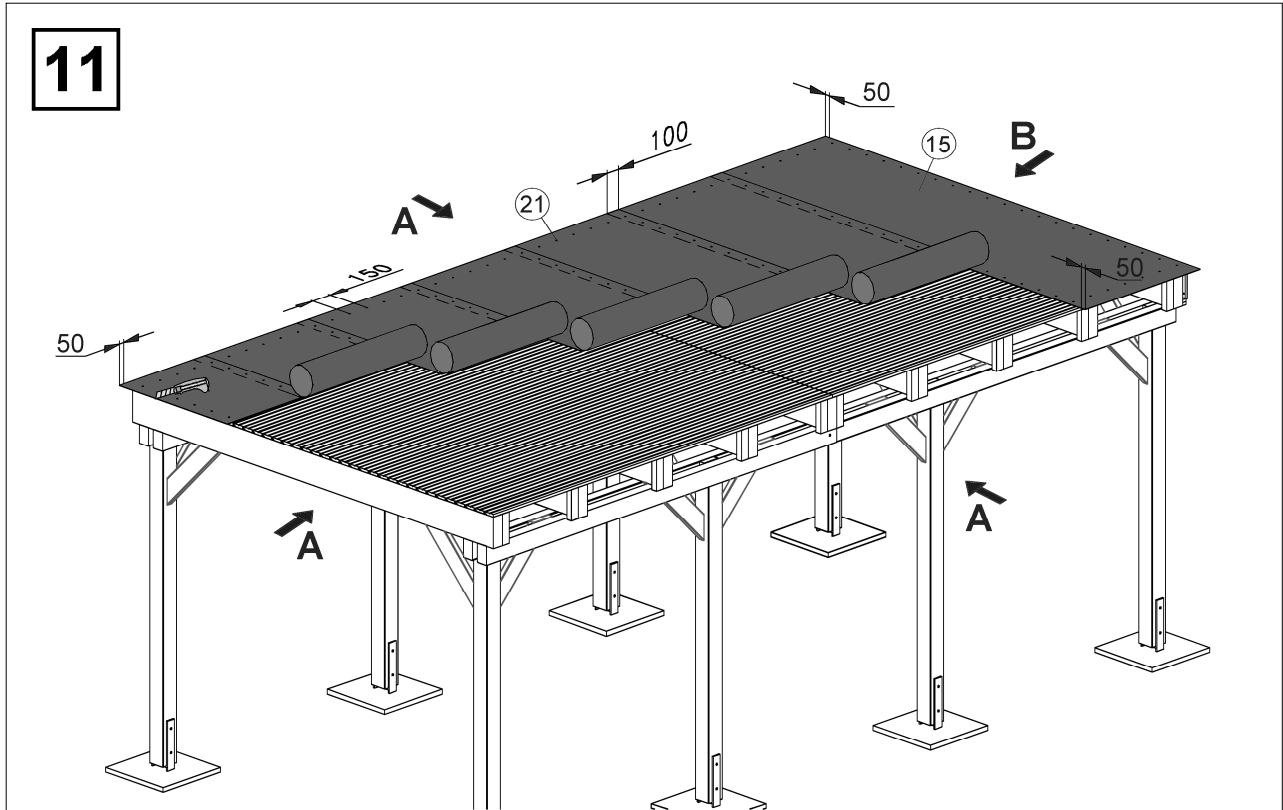
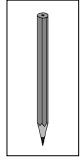
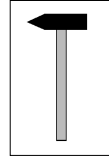
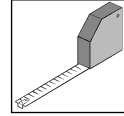
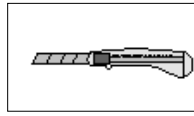

de	Ortgangbrett
en	Verge board
fr	bordure de rive
it	asse di passeggio

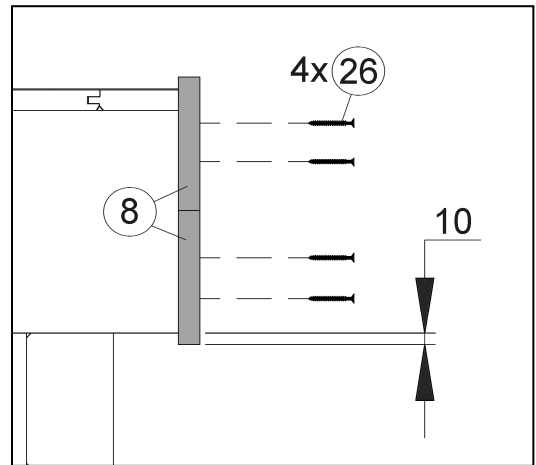
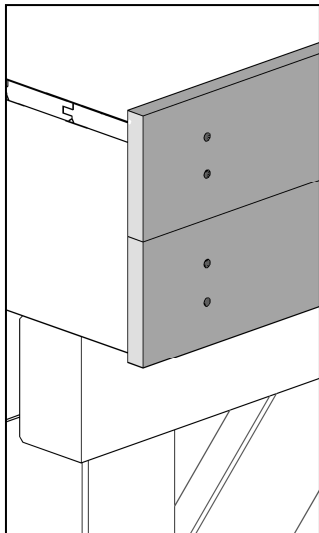
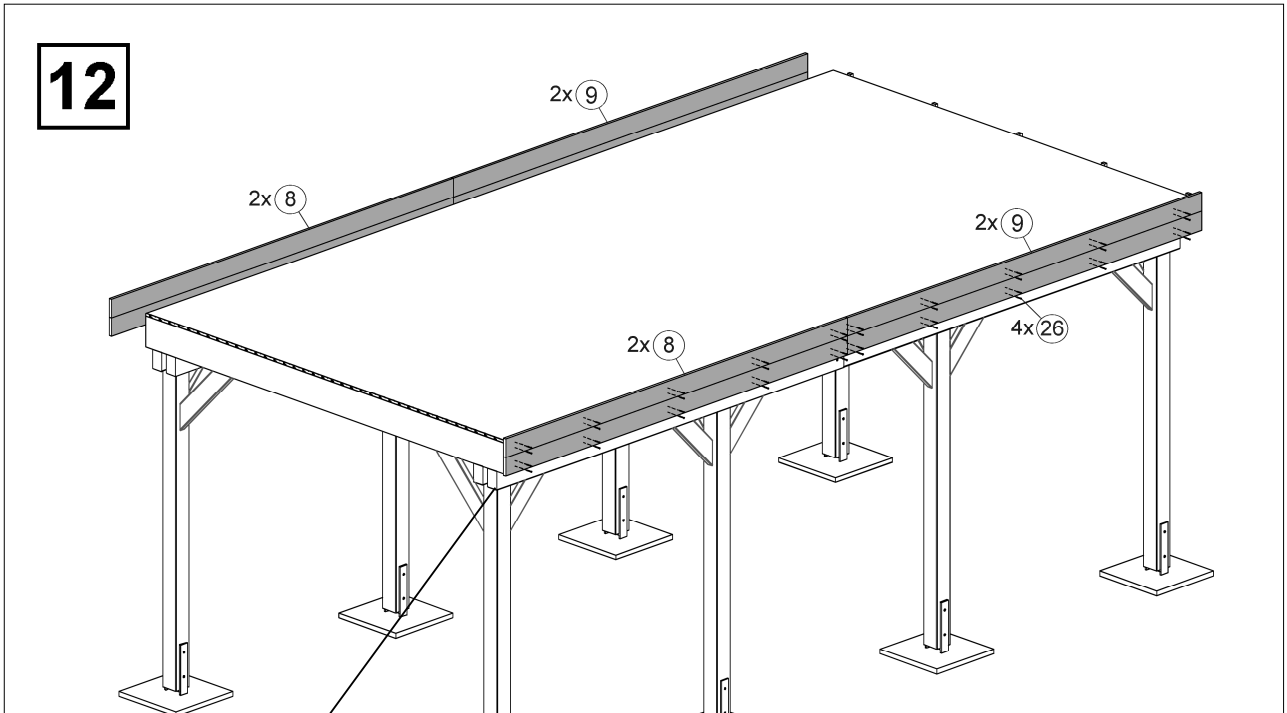
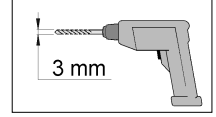
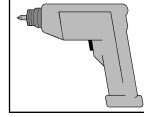
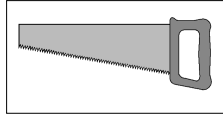
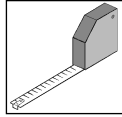
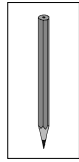

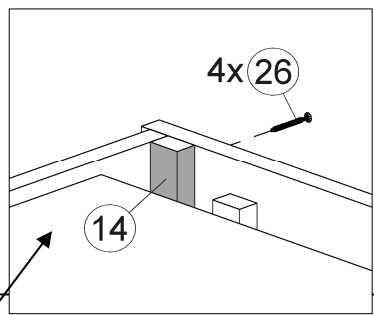
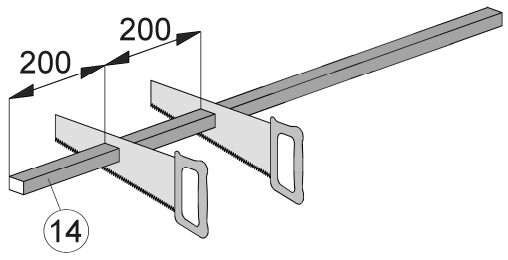
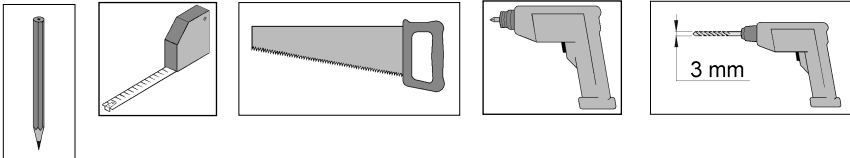

**13**

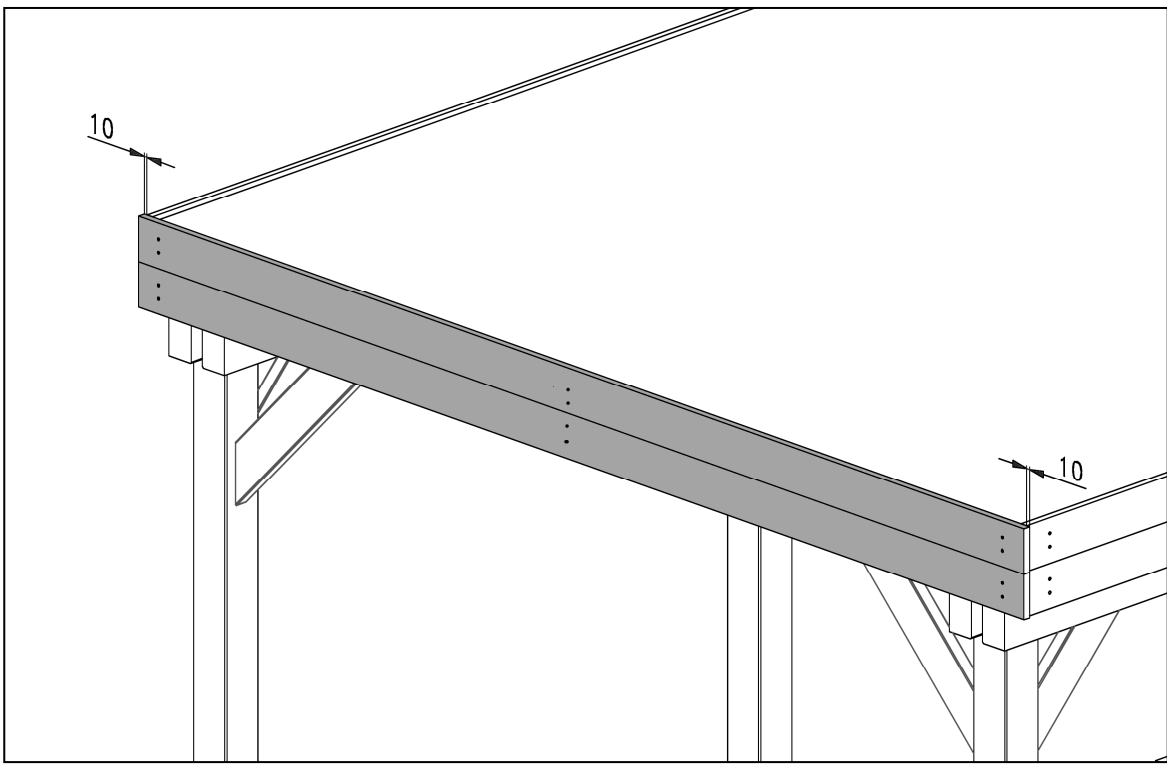
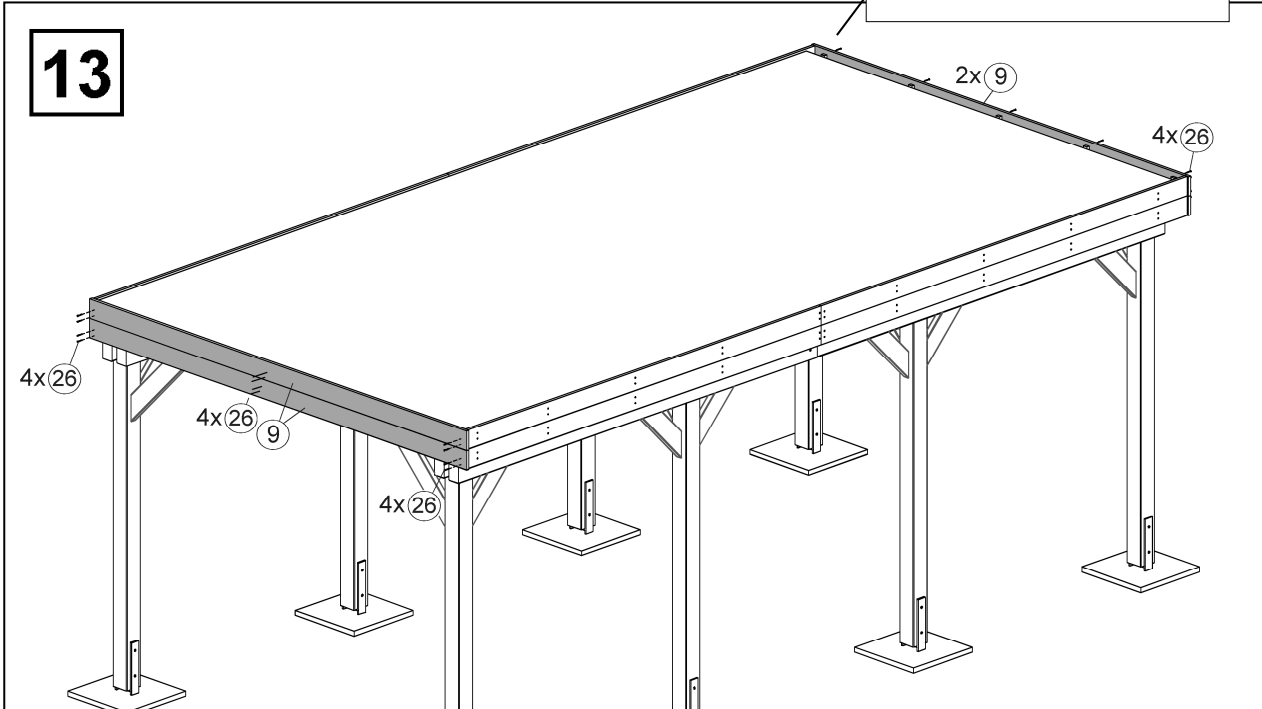

de	Deckleiste
en	Ceiling batten
fr	latte de recouvrement
it	listello di copertura

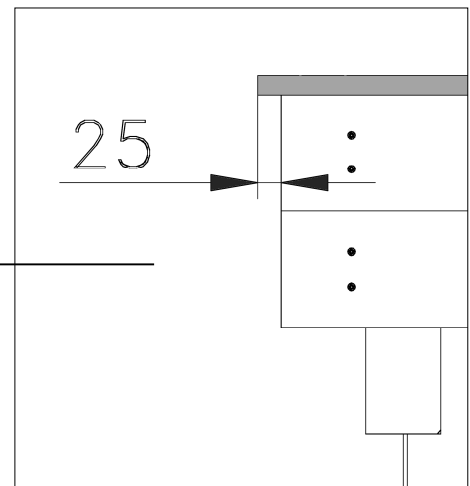
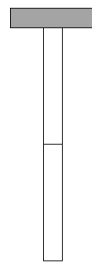
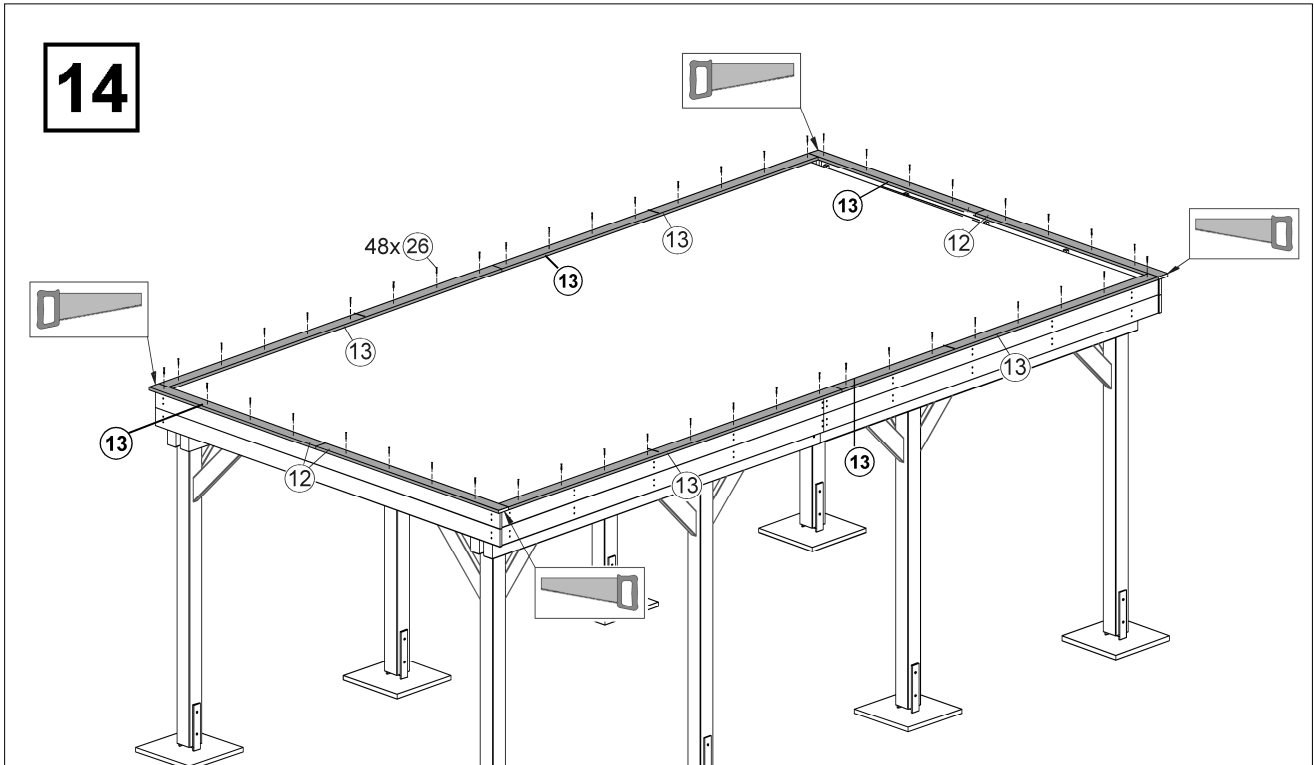
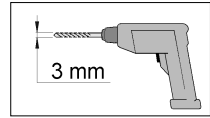
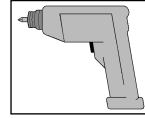
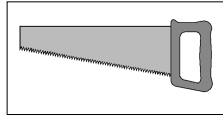
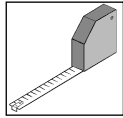
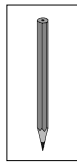



weka Holzbau GmbH, Johannesstr. 16  
D-17034 Neubrandenburg  
Tel.: 0395 42908-0  
Fax: 0395 42908-83  
E-Mail: [Info@weka-Holzbau.com](mailto:Info@weka-Holzbau.com)

**MA Art.-Nr.: 800.0286.08.66**